

## Product advantages



The combination of a high degree of protection and material PC UL 94 V0 (f1 UL 746C) characteristics allows outdoor use.

Material corresponds to the set of requirements R 22 according to DIN EN 45545-2 of risk level HL3.



The mounting brackets are moulded-on directly to the aluminium base. They can be retrofitted separately to the plastic base.



A mast fixing is available as an optional extra.

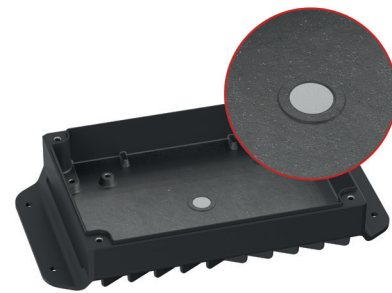

The base has a moulded-on insertion opening for a pressure compensation membrane which can be factory-activated.



The transparent function lid provides a view of the enclosure interior or built-in displays.

# BoVersa

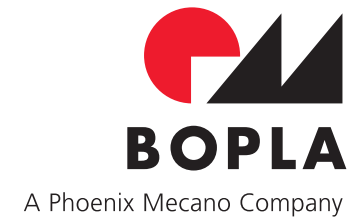

## Applications

The enclosure can be used for applications in the hand, on the desktop, on the wall and on the mast.

Bopla Gehäuse Systeme GmbH  
Borsigstraße 17-25 | D-32257 Bünde  
Phone +49 (0) 5223-969-0 | Fax +49 (0) 5223-969-100  
info@bopla.de | www.bopla.de

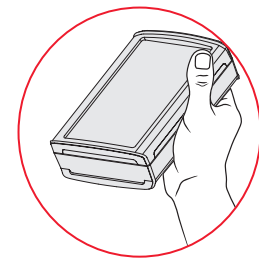

Hand-held enclosures

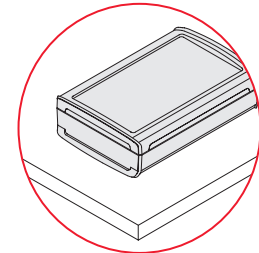

Desktop enclosures

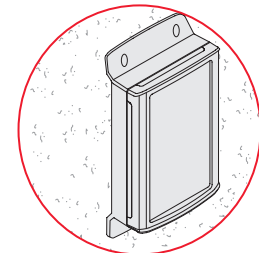

Wall enclosures

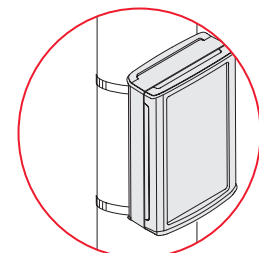

Mast enclosures

# BoVersa

Enclosure for IoT or embedded systems



Product advantages



The three-part enclosure assembly base, function lid and design cover. These three elements can be combined in any way required.

With the 4 basic sizes you have endless combination possibilities. The enclosure sizes fits with standard (touch) display formats.



A metal base and a plastic lid create the perfect combination for wireless applications which require cooling.



An enclosure base made of diecast aluminium with moulded-on cooling fins and fixing brackets.

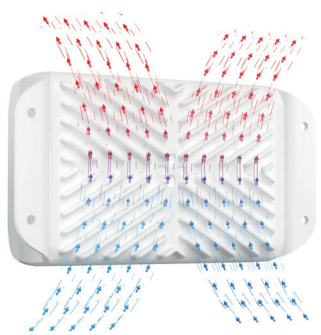

The symmetrical design of the cooling fins makes possible an optimal flow of air in both the horizontal and vertical mounting positions.



The frame-shaped design cover is perfect for integrating keypads and displays, while the closed variant makes possible a clean look or individual designs.

# BoVersa



**Design:**

- Black, similar to RAL 9005
- White, similar to RAL 9016

Special colours on request

**Protection class:**

IP66 / 68 (1.2 m - 2 h) DIN EN 60529  
Impact strength IK08 IEC 62262  
7 Joule EN 60079-0

**Material:**

Plastic parts: PC UL 94 V-0  
suitable for outdoor use;  
f1 listing according to UL 746 C  
Seal: PU foamed

Materials according to requirement set R1 or R7 according to DIN EN 45545-2 of the risk level HL3.

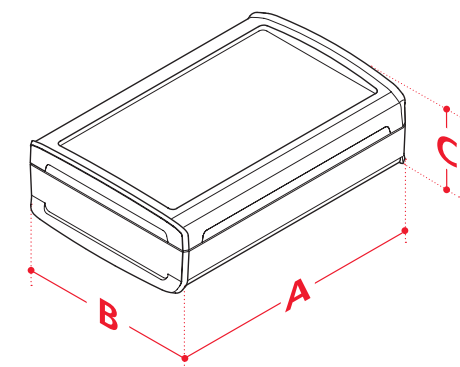

**Dimensions**

Model	A	B	C
BoVersa 120903 / 3.5"	125	88	34
BoVersa 171204 / 5"	170	120	44
BoVersa 211405 / 7"	210	140	54
BoVersa 281906 / 10.1"	275	185	64

- The closed design cover changes almost unlimited the look through individual processing
- The transparent functional lid provides a view inside the enclosure or built-in displays
- No visible enclosure screws
- Enclosure base made of aluminum with molded cooling function
- Highlights can be created by combining enclosure parts in different colors – on request also customized
- The translucent functional lid enables impressive lighting effects and realizes status signaling

**Enclosure combinations**

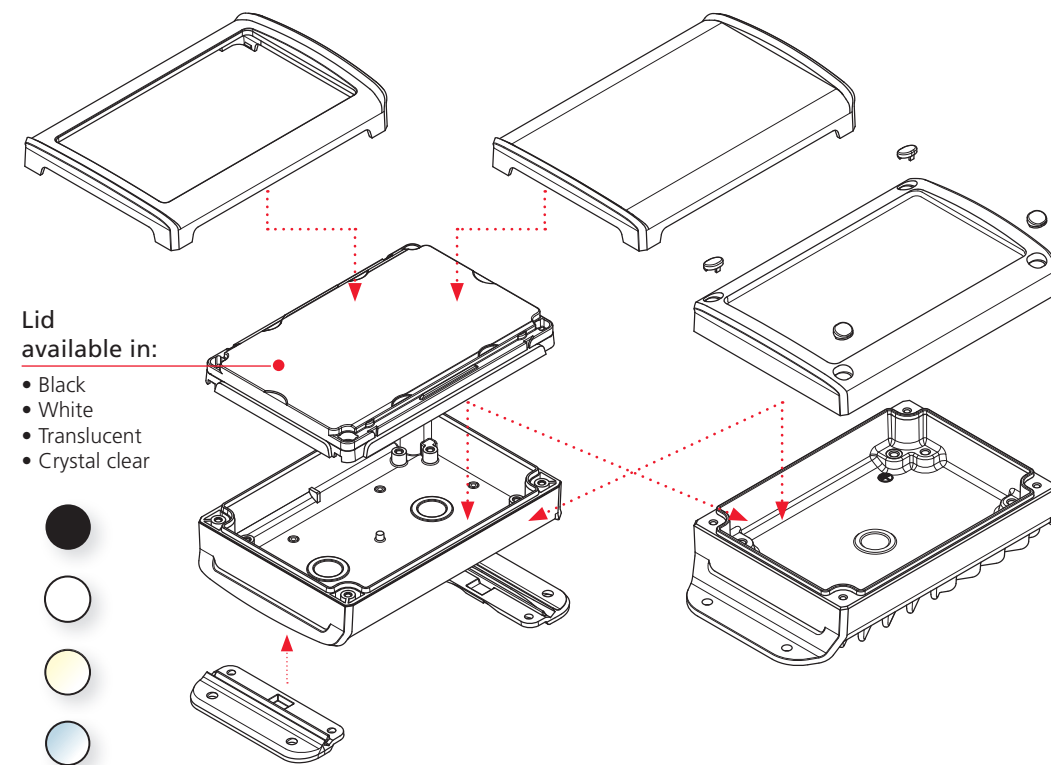

**Enclosure sizes**

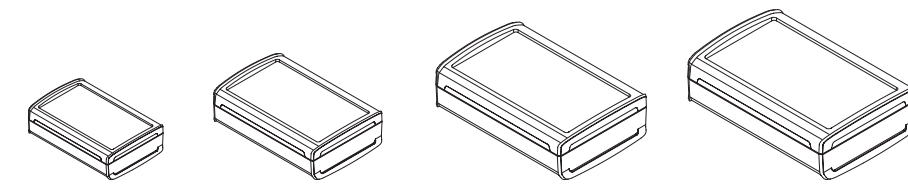

**Display sizes**

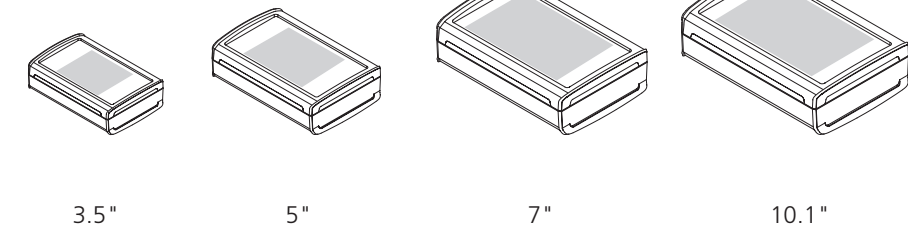

Product advantages

Combine different-coloured enclosure parts and create colourful accents. Combine any way you choose.



The enclosure parts are combinable using different colours. Photometric design accents can be created by the use of the transparent and translucent function lids.



Individual processing of the closed design cover allows almost unlimited changes to the look.



A diecast aluminium lid is also available for applications which require extra mechanical stability – the lid screws are concealed under covers.

